

# Model BMC153/BMCW172

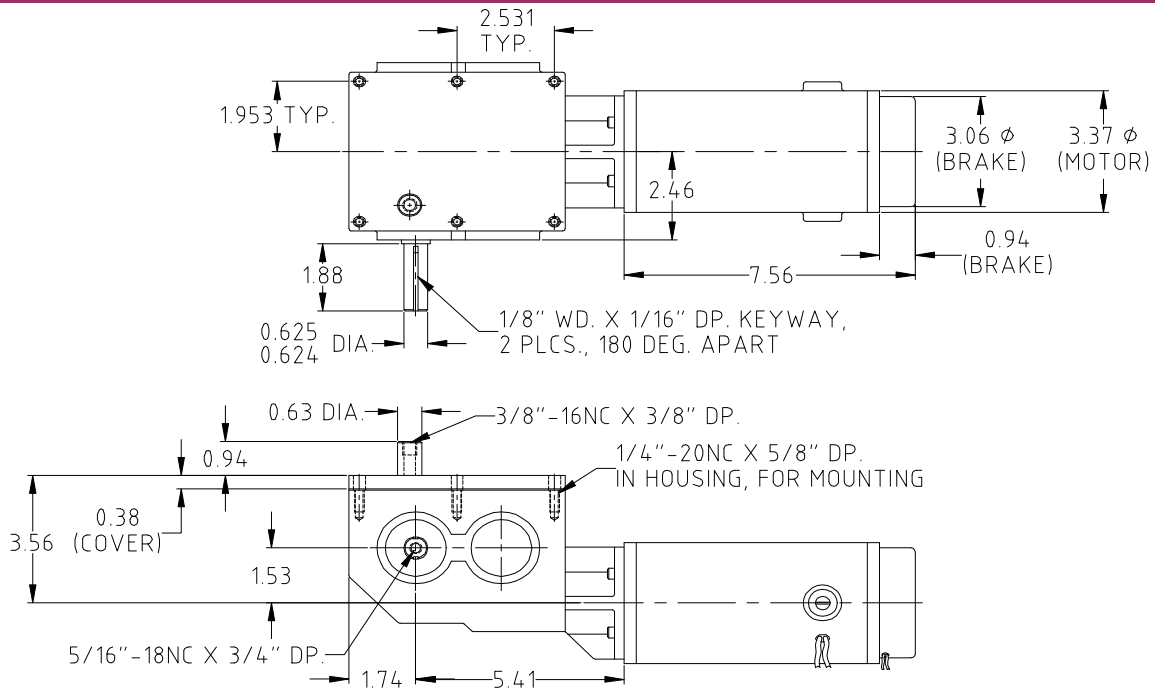

Part No.	Ratio	Output R.P.M.	Motor R.P.M.	Voltage	Hp	Duty	Torque	Motor Dia	Weight	Man. Rel. Brake
BMC153-3563B-21.2	21.2	142	3000	24 VDC	1/4	Cont.	111 in-lbs.	3-3/8"	17 lbs.	15 in-lbs.
BMC153-3563B-27.2	27.2	110	3000	24 VDC	1/4	Cont.	143 in-lbs.	3-3/8"	17 lbs.	15 in-lbs.

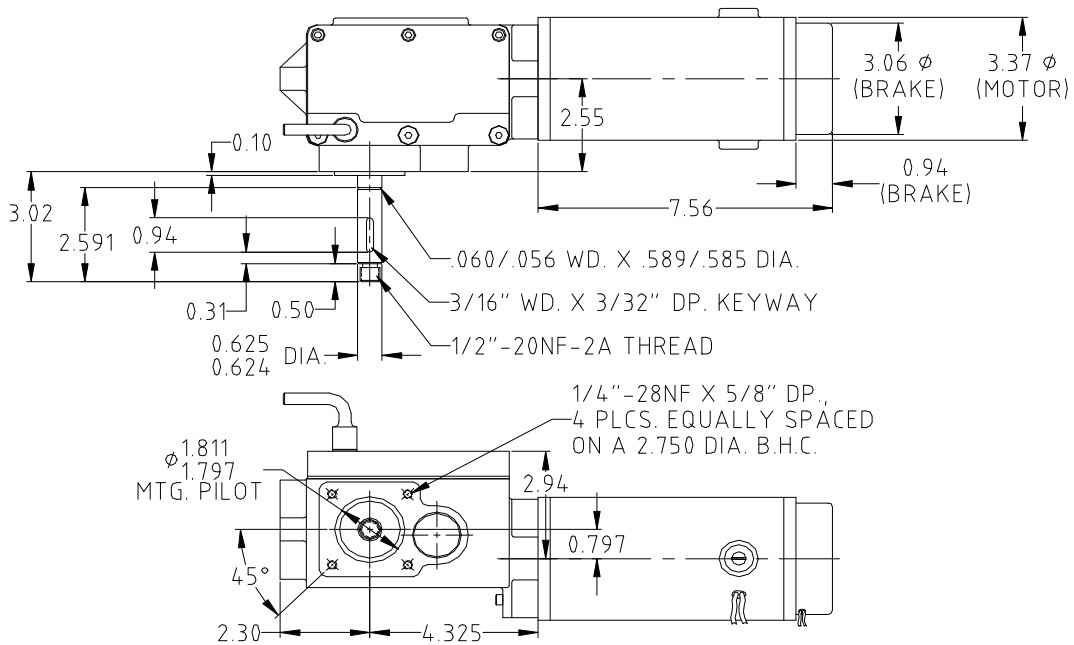

Part No.	Ratio	Output R.P.M.	Motor R.P.M.	Voltage	Hp	Duty	Torque	Motor Dia	Weight	Man. Rel. Brake
BMCW172-4023C-20	20	150	3000	24 VDC	1/4	Cont.	105 in-lbs.	3-3/8"	15.1 lbs.	15 in-lbs.

- Custom output shafts and ratios are available upon request.
- Dimensions are for reference only, request certified prints for construction purposes.
- Units are available in R.H. and L.H. configurations (L.H. is shown).



A Division of Imperial Electric