

Model BMC133C/BMCXPR

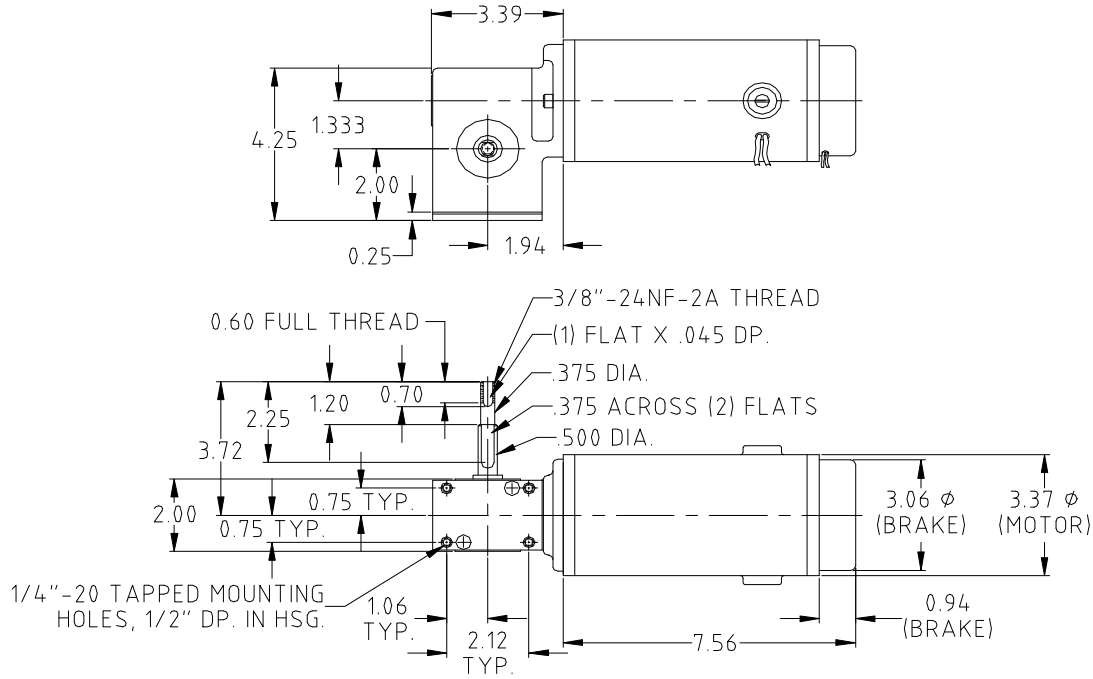

Part No.	Ratio	Output R.P.M.	Motor R.P.M.	Voltage	Hp	Duty	Torque	Motor Dia	Weight	Man. Rel. Brake
BMC133C-1901C-12.33	12.33	243	3000	24 VDC	1/4	Cont.	65 in-lbs.	3-3/8"	10 lbs.	15 in-lbs.

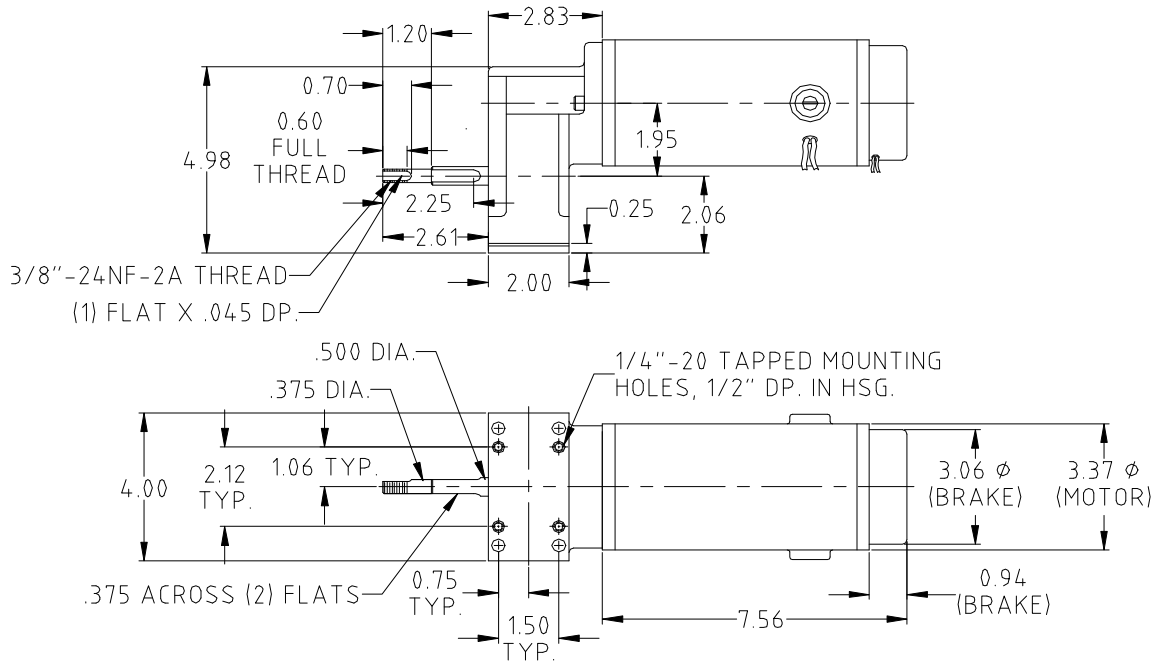

Part No.	Ratio	Output R.P.M.	Motor R.P.M.	Voltage	Hp	Duty	Torque	Motor Dia	Weight	Man. Rel. Brake
BMCXPR-2716C-11.25	11.25	267	3000	24 VDC	1/4	Cont.	59 in-lbs.	3-3/8"	11 lbs.	15 in-lbs.

- Custom output shafts and ratios are available upon request.
- Dimensions are for reference only, request certified prints for construction purposes.
- BMC133C is available in R.H. and L.H. configurations (L.H. is shown).



A Division of Imperial Electric